

- Qualified for Automotive Applications
- Customer-Specific Configuration Control Can Be Supported Along With Major-Change Approval
- ESD Protection Exceeds 2000 V Per MIL-STD-883, Method 3015; Exceeds 200 V Using Machine Model (C = 200 pF, R = 0)
- Supply Current of 220 nA (Typ)
- Precision Supply Voltage Supervision Range: 1.8 V, 2.5 V, 3.0 V, 3.3 V
- Power-On Reset Generator With Selectable Delay Time of 10 ms or 200 ms
- Push/Pull $\overline{\text{RESET}}$ Output (TPS3836), RESET Output (TPS3837), or Open-Drain $\overline{\text{RESET}}$ Output (TPS3838)
- Manual Reset
- 5-Pin SOT-23 Package
- Temperature Range: -40°C to 125°C
- Applications Include
 - Applications Using Automotive Low-Power DSPs, Microcontrollers, or Microprocessors
 - Battery-Powered Equipment
 - Intelligent Instruments
 - Wireless Communication Systems
 - Automotive Systems

description

The TPS3836, TPS3837, TPS3838 families of supervisory circuits provide circuit initialization and timing supervision, primarily for DSP and processor-based systems.

During power on, $\overline{\text{RESET}}$ is asserted when the supply voltage V_{DD} becomes higher than 1.1 V. Thereafter, the supervisory circuit monitors V_{DD} and keeps $\overline{\text{RESET}}$ output active as long as V_{DD} remains below the threshold voltage V_{IT} . An internal timer delays the return of the output to the inactive state (high) to ensure proper system reset. The delay time starts after V_{DD} has risen above the threshold voltage V_{IT} .

When CT is connected to GND a fixed delay time of typical 10 ms is asserted. When connected to V_{DD} the delay time is typically 200 ms.

When the supply voltage drops below the threshold voltage V_{IT} , the output becomes active (low) again.

All the devices of this family have a fixed-sense threshold voltage V_{IT} set by an internal voltage divider.

The TPS3836 has an active-low push-pull $\overline{\text{RESET}}$ output. The TPS3837 has active-high push-pull RESET, and TPS3838 integrates an active-low open-drain $\overline{\text{RESET}}$ output.

TPS3836, TPS3838
 DBV PACKAGE
 (TOP VIEW)

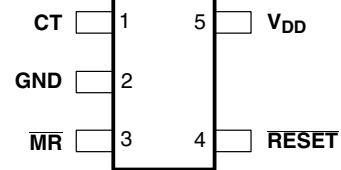

TPS3837
 DBV PACKAGE
 (TOP VIEW)

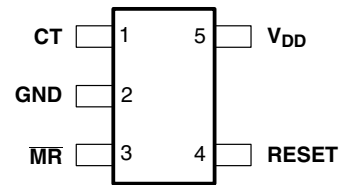

Please be aware that an important notice concerning availability, standard warranty, and use in critical applications of Texas Instruments semiconductor products and disclaimers thereto appears at the end of this data sheet.

PRODUCTION DATA information is current as of publication date. Products conform to specifications per the terms of Texas Instruments standard warranty. Production processing does not necessarily include testing of all parameters.



POST OFFICE BOX 655303 • DALLAS, TEXAS 75265

Copyright © 2007, Texas Instruments Incorporated

TPS3836E18-Q1 / J25-Q1 / H30-Q1 / L30-Q1 / K33-Q1
TPS3837E18-Q1 / J25-Q1 / L30-Q1 / K33-Q1, TPS3838E18-Q1 / J25-Q1 / L30-Q1 / K33-Q1
NANOPOWER SUPERVISORY CIRCUITS

SGLS141A – DECEMBER 2002 – REVISED JANUARY 2007

description (continued)

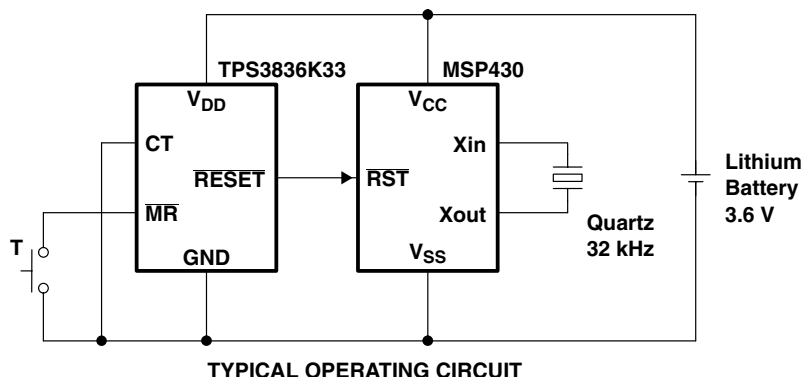

The product spectrum is designed for supply voltages of 1.8 V, 2.5 V, 3 V, and 3.3 V. The circuits are available in a 5-pin SOT-23 package. The TPS3836-Q-Q1, TPS3837-Q-Q1, TPS3838-Q-Q1 families are characterized for operation over a temperature range of -40°C to 125°C .

PACKAGE INFORMATION

T_A	DEVICE NAME	THRESHOLD VOLTAGE	SYMBOL
-40°C to 125°C	TPS3836E18QDBVRQ1†	1.71 V	PDNQ
	TPS3836J25QDBVRQ1†	2.25 V	PDSQ
	TPS3836H30QDBVRQ1†	2.79 V	PHRQ
	TPS3836L30QDBVRQ1†	2.64 V	PCAQ
	TPS3836K33QDBVRQ1†	2.93 V	PDTQ
	TPS3837E18QDBVRQ1†	1.71 V	PDOQ
	TPS3837J25QDBVRQ1†	2.25 V	PDRQ
	TPS3837L30QDBVRQ1†	2.64 V	PCBQ
	TPS3837K33QDBVRQ1†	2.93 V	PDUQ
	TPS3838E18QDBVRQ1†	1.71 V	PDQQ
	TPS3838J25QDBVRQ1†	2.25 V	PDPQ
	TPS3838L30QDBVRQ1†	2.64 V	PCCQ
	TPS3838K33QDBVRQ1†	2.93 V	PDVQ

† DBVR indicates tape and reel of 3000 parts.

ORDERING INFORMATION

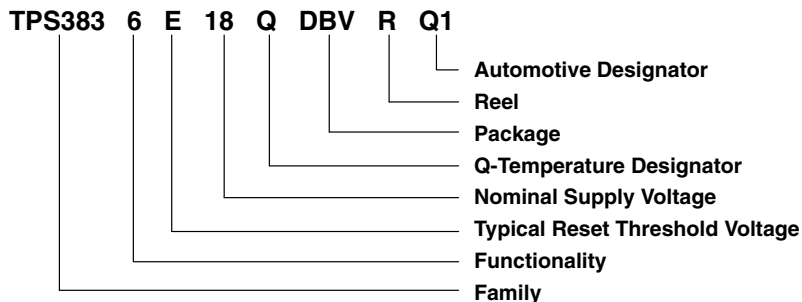

FUNCTION TABLE TPS3836, TPS3837, TPS3838

MR	$V_{DD} > V_{IT}$	RESET [†]	RESET [‡]
L	0	L	H
L	1	L	H
H	0	L	H
H	1	H	L

† TPS3836 and TPS3838

‡ TPS3837

functional block diagram

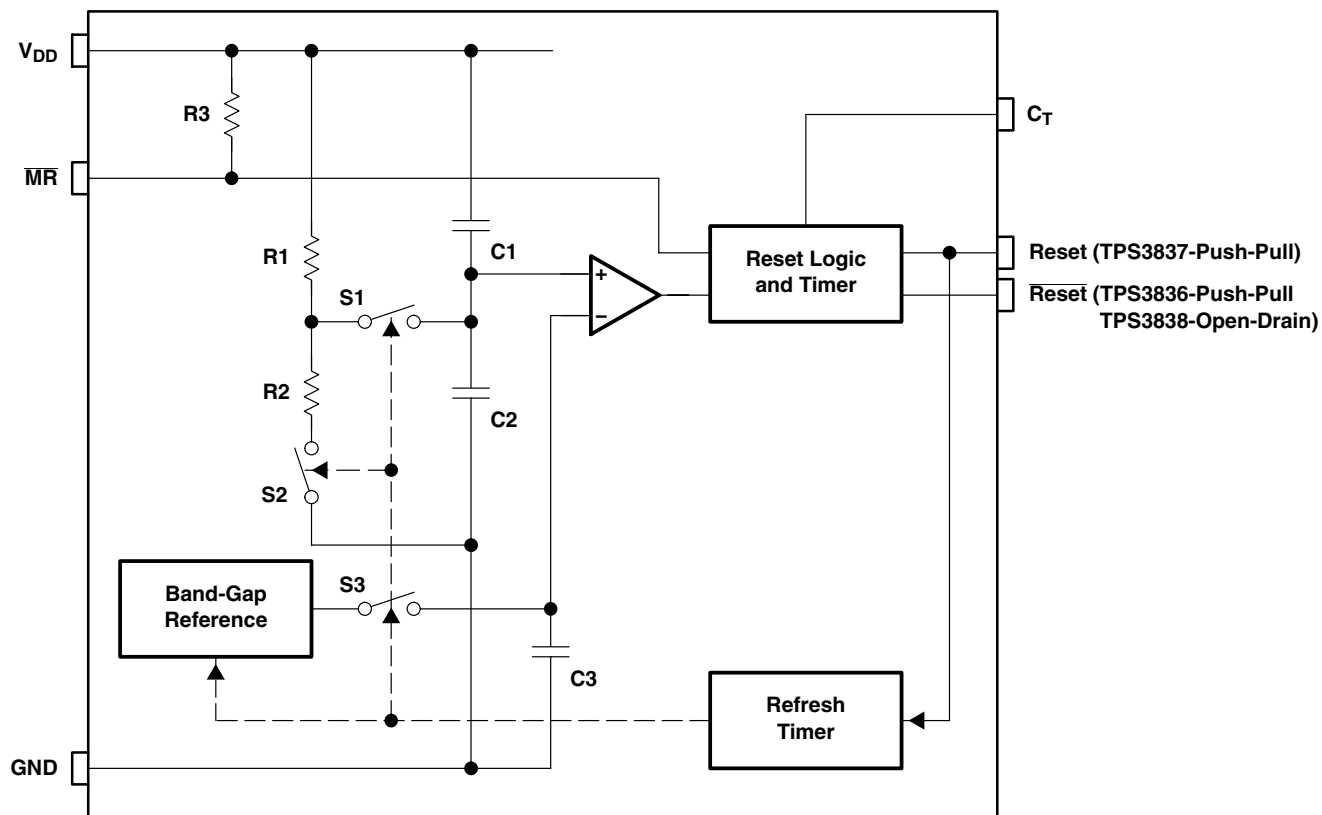

TPS3836E18-Q1 / J25-Q1 / H30-Q1 / L30-Q1 / K33-Q1
 TPS3837E18-Q1 / J25-Q1 / L30-Q1 / K33-Q1, TPS3838E18-Q1 / J25-Q1 / L30-Q1 / K33-Q1
 NANOPOWER SUPERVISORY CIRCUITS

SGLS141A – DECEMBER 2002 – REVISED JANUARY 2007

timing diagram

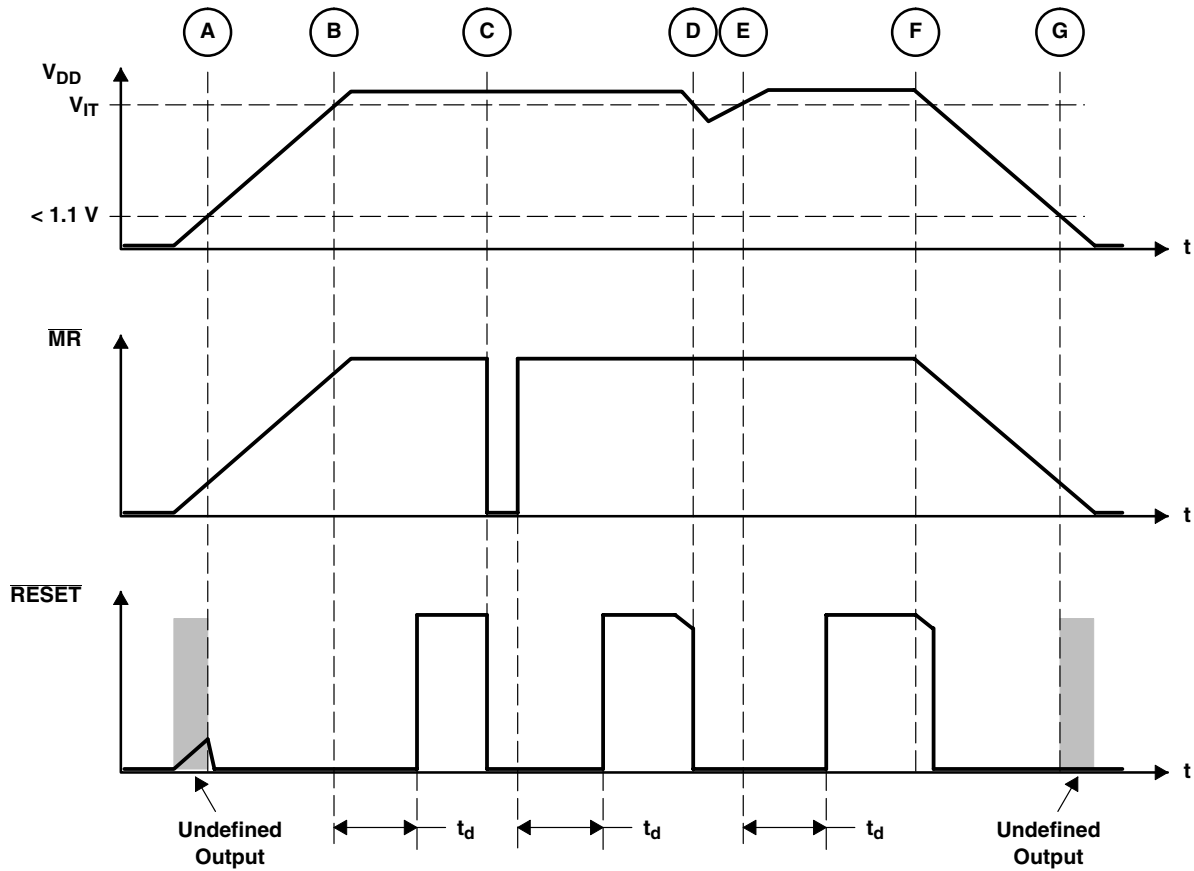

TPS3836E18-Q1 / J25-Q1 / H30-Q1 / L30-Q1 / K33-Q1
TPS3837E18-Q1 / J25-Q1 / L30-Q1 / K33-Q1, TPS3838E18-Q1 / J25-Q1 / L30-Q1 / K33-Q1
NANOPOWER SUPERVISORY CIRCUITS

SGLS141A – DECEMBER 2002 – REVISED JANUARY 2007

absolute maximum ratings over operating free-air temperature range (unless otherwise noted)†

Supply voltage, V_{DD} (see Note 1)	7 V
All other pins (see Note 1)	-0.3 V to 7 V
Maximum low output current, I_{OL}	5 mA
Maximum high output current, I_{OH}	-5 mA
Input clamp current, I_{IK} ($V_I < 0$ or $V_I > V_{DD}$)	± 10 mA
Output clamp current, I_{OK} ($V_O < 0$ or $V_O > V_{DD}$)	± 10 mA
Continuous total power dissipation	See Dissipation Rating Table
Operating free-air temperature range, T_A	-40°C to 125°C
Storage temperature range, T_{stg}	-65°C to 150°C
Soldering temperature	260°C

† Stresses beyond those listed under “absolute maximum ratings” may cause permanent damage to the device. These are stress ratings only, and functional operation of the device at these or any other conditions beyond those indicated under “recommended operating conditions” is not implied. Exposure to absolute-maximum-rated conditions for extended periods may affect device reliability.

NOTE 1: All voltage values are with respect to GND. For reliable operation, the device must not be operated at 7 V for more than $t=1000$ h continuously

DISSIPATION RATING TABLE

PACKAGE	$T_A < 25^\circ\text{C}$ POWER RATING	DERATING FACTOR ABOVE $T_A = 25^\circ\text{C}$	$T_A = 70^\circ\text{C}$ POWER RATING	$T_A = 85^\circ\text{C}$ POWER RATING	$T_A = 125^\circ\text{C}$ POWER RATING
DBV	437 mW	3.5 mW/°C	280 mW	227 mW	87 mW

recommended operating conditions at specified temperature range

	MIN	MAX	UNIT
Supply voltage, V_{DD}	1.6	6	V
Input voltage, V_I	0	$V_{DD} + 0.3$	V
High-level input voltage, V_{IH}	$0.7 \times V_{DD}$		V
Low-level input voltage, V_{IL}		$0.3 \times V_{DD}$	V
Input transition rise and fall rate at \overline{MR} , $\Delta t/\Delta V$		100	ns/V
Operating free-air temperature range, T_A	-40	125	°C



TPS3836E18-Q1 / J25-Q1 / H30-Q1 / L30-Q1 / K33-Q1
TPS3837E18-Q1 / J25-Q1 / L30-Q1 / K33-Q1, TPS3838E18-Q1 / J25-Q1 / L30-Q1 / K33-Q1
NANOPOWER SUPERVISORY CIRCUITS

SGLS141A – DECEMBER 2002 – REVISED JANUARY 2007

electrical characteristics over recommended operating conditions (unless otherwise noted)

PARAMETER		TEST CONDITION		MIN	TYP	MAX	UNIT
V _{OH}	High-level output voltage	RESET (TPS3836)	V _{DD} = 3.3 V, I _{OH} = -2 mA	0.8 × V _{DD}			V
			V _{DD} = 6 V, I _{OH} = -3 mA				
		RESET (TPS3837)	V _{DD} = 1.8 V, I _{OH} = -1 mA				
			V _{DD} = 3.3 V, I _{OL} = -2 mA				
V _{OL}	Low-level output voltage	RESET (TPS3836/8)	V _{DD} = 1.8 V, I _{OL} = 1 mA			0.4	V
			V _{DD} = 3.3 V, I _{OL} = 2 mA				
		RESET (TPS3837)	V _{DD} = 3.3 V, I _{OL} = 2 mA				
			V _{DD} = 6 V, I _{OL} = 3 mA				
Power-up reset voltage (see Note 2)		TPS3836/8	V _{DD} ≥ 1.1 V, I _{OL} = 50 μA	0.8 × V _{DD}		0.2	V
		TPS3837	V _{DD} ≥ 1.1 V, I _{OH} = -50 μA				
V _{IT}	Negative-going input threshold voltage (see Note 3)	TPS383xE18		1.64	1.71	1.76	V
		TPS383xJ25		2.16	2.25	2.30	
		TPS383xH30		2.70	2.79	2.85	
		TPS383xL30		2.54	2.64	2.71	
		TPS383xK33		2.82	2.93	3.10	
V _{hys}	Hysteresis at V _{DD} input	1.7 V < V _{IT} < 2.5 V		30			mV
		2.5 V < V _{IT} < 3.5 V		40			
		3.5 V < V _{IT} < 5 V		50			
I _{IH}	High-level input current	MR̄ (see Note 4)	MR̄ = 0.7 × V _{DD} , V _{DD} = 6 V	-40	-60	-100	μA
		CT	CT = V _{DD} = 6 V	-25		25	nA
I _{IL}	Low-level input current	MR̄ (see Note 4)	MR̄ = 0 V, V _{DD} = 6 V	-130	-200	-340	μA
		CT	CT = 0 V, V _{DD} = 6 V	-25		25	nA
I _{OH}	High-level output current	TPS3838	V _{DD} = V _{IT} + 0.2 V, V _{OH} = V _{DD}			25	nA
I _{DD}	Supply current	V _{DD} > V _{IT} , V _{DD} < 3 V			220	500	nA
		V _{DD} > V _{IT} , V _{DD} > 3 V			250	550	nA
		V _{DD} < V _{IT}			10	25	μA
Internal pullup resistor at MR̄					30		kΩ
C _I	Input capacitance at MR̄, CT	V _I = 0 V to V _{DD}			5		pF

- NOTES: 2. The lowest voltage at which RESET output becomes active. t_r, V_{DD} ≥ 15 μs/V
3. To ensure best stability of the threshold voltage, a bypass capacitor (ceramic, 0.1 μF) should be placed near the supply terminal.
4. If manual reset is unused, MR should be connected to V_{DD} to minimize current consumption.



TPS3836E18-Q1 / J25-Q1 / H30-Q1 / L30-Q1 / K33-Q1
TPS3837E18-Q1 / J25-Q1 / L30-Q1 / K33-Q1, TPS3838E18-Q1 / J25-Q1 / L30-Q1 / K33-Q1
NANOPOWER SUPERVISORY CIRCUITS

SGLS141A – DECEMBER 2002 – REVISED JANUARY 2007

timing requirements at $R_L = 1\text{ M}\Omega$, $C_L = 50\text{ pF}$, $T_A = 25^\circ\text{C}$

PARAMETER		TEST CONDITIONS	MIN	TYP	MAX	UNIT
t_w	Pulse width	$V_{IH} = V_{IT} + 0.2\text{ V}$, $V_{IL} = V_{IT} - 0.2\text{ V}$	6			μs
		$V_{DD} \geq V_{IT} + 0.2\text{ V}$, $V_{IH} = 0.7 \times V_{DD}$, $V_{IL} = 0.7 \times V_{DD}$	1			μs

switching characteristics at $R_L = 1\text{ M}\Omega$, $C_L = 50\text{ pF}$, $T_A = 25^\circ\text{C}$

PARAMETER		TEST CONDITIONS	MIN	TYP	MAX	UNIT
t_d	Delay time	$V_{DD} \geq V_{IT} + 0.2\text{ V}$, $\overline{\text{MR}} = 0.7 \times V_{DD}$, $\text{CT} = \text{GND}$, See timing diagram	5	10	15	ms
		$V_{DD} \geq V_{IT} + 0.2\text{ V}$, $\overline{\text{MR}} = 0.7 \times V_{DD}$, $\text{CT} = V_{DD}$, See timing diagram	100	200	300	
t_{PHL}	Propagation (delay) time, high-to-low-level output	V_{DD} to $\overline{\text{RESET}}$ delay (TPS3836, TPS3838)			10	μs
					50	
t_{PLH}	Propagation (delay) time, low-to-high-level output	V_{DD} to $\overline{\text{RESET}}$ delay (TPS3837)			10	μs
					50	
t_{PHL}	Propagation (delay) time, high-to-low-level output	$\overline{\text{MR}}$ to $\overline{\text{RESET}}$ delay (TPS3836, TPS3838)			0.1	μs
t_{PLH}	Propagation (delay) time, low-to-high-level output	$\overline{\text{MR}}$ to $\overline{\text{RESET}}$ delay (TPS3837)			0.1	μs

TYPICAL CHARACTERISTICS

Table of Graphs

			FIGURE
I_{DD}	Supply current	vs Supply voltage	1
I_{MR}	Manual reset current	vs Manual reset voltage	2
V_{OL}	Low-level output voltage	vs Low-level output current	3
V_{OH}	High-level output voltage	vs High-level output current	4
	Normalized reset threshold voltage	vs Free-air temperature	5
	Minimum pulse duration at V_{DD}	vs V_{DD} Threshold overdrive	6



TYPICAL CHARACTERISTICS

SUPPLY CURRENT
 vs
 SUPPLY VOLTAGE

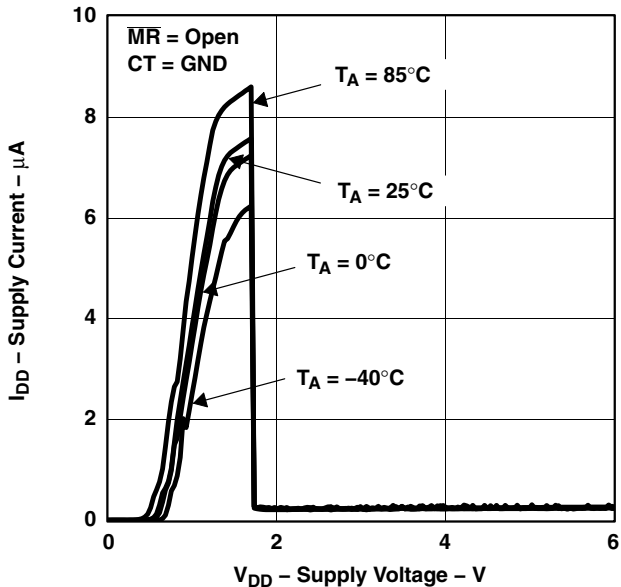

Figure 1

MANUAL RESET CURRENT
 vs
 MANUAL RESET VOLTAGE

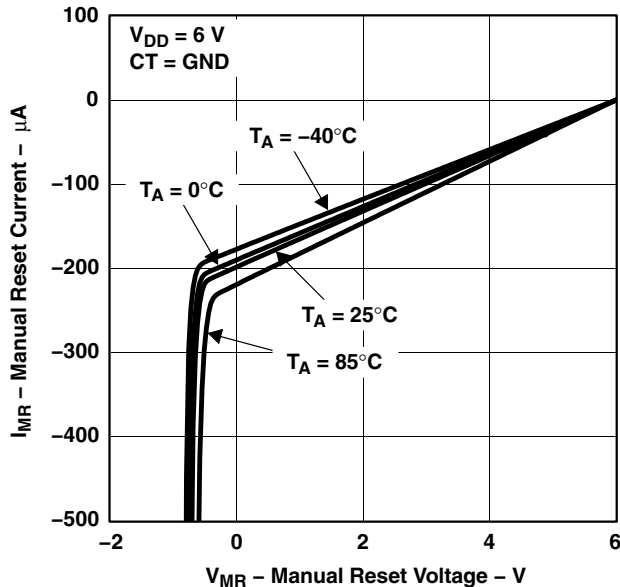

Figure 2

LOW-LEVEL OUTPUT VOLTAGE
 vs
 LOW-LEVEL OUTPUT CURRENT

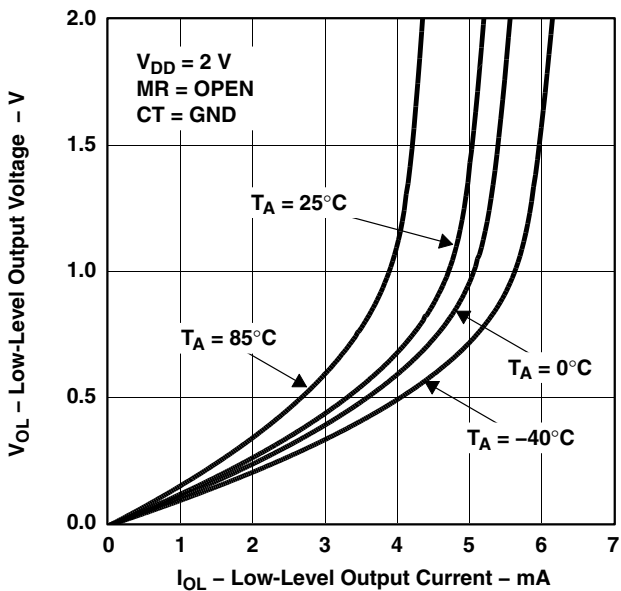

Figure 3

HIGH-LEVEL OUTPUT VOLTAGE
 vs
 HIGH-LEVEL OUTPUT CURRENT

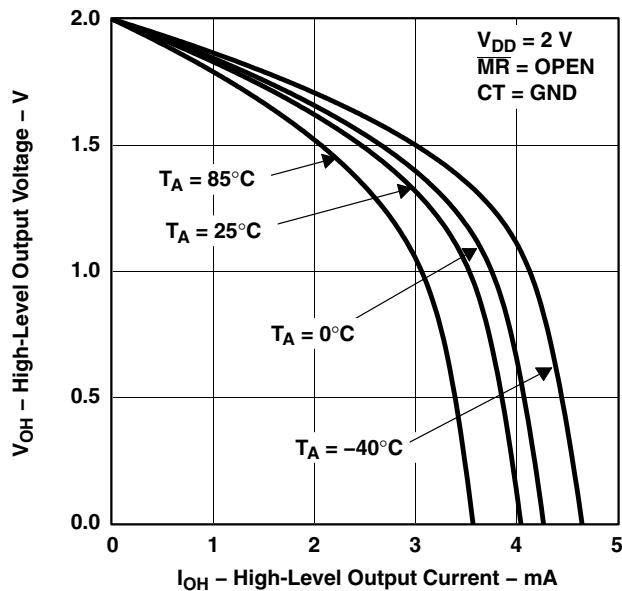

Figure 4

TYPICAL CHARACTERISTICS

**NORMALIZED RESET THRESHOLD VOLTAGE
 vs
 FREE-AIR TEMPERATURE**

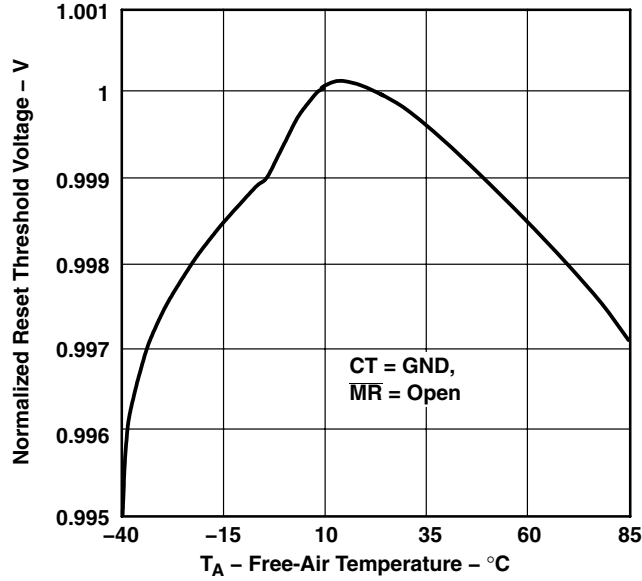

Figure 5

**MINIMUM PULSE DURATION AT V_{DD}
 vs
 V_{DD} THRESHOLD OVERDRIVE**

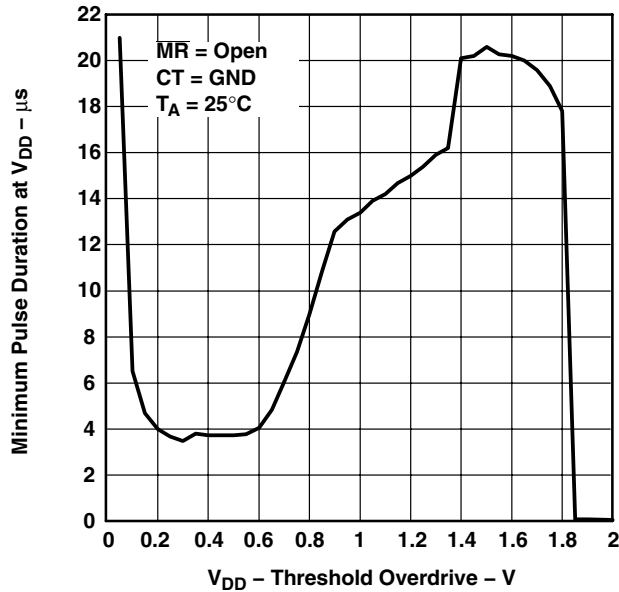

Figure 6

PACKAGING INFORMATION

Orderable Device	Status (1)	Package Type	Package Drawing	Pins	Package Qty	Eco Plan (2)	Lead/Ball Finish	MSL Peak Temp (3)	Op Temp (°C)	Top-Side Markings (4)	Samples
2U3836E18QDBVRG4Q1	ACTIVE	SOT-23	DBV	5	3000	Green (RoHS & no Sb/Br)	CU NIPDAU	Level-1-260C-UNLIM	-40 to 125	PDNQ	Samples
2U3836H30QDBVRG4Q1	ACTIVE	SOT-23	DBV	5	3000	Green (RoHS & no Sb/Br)	CU NIPDAU	Level-1-260C-UNLIM	-40 to 125	PHRQ	Samples
2U3836J25QDBVRG4Q1	ACTIVE	SOT-23	DBV	5	3000	Green (RoHS & no Sb/Br)	CU NIPDAU	Level-1-260C-UNLIM	-40 to 125	PDSQ	Samples
2U3836K33QDBVRG4Q1	ACTIVE	SOT-23	DBV	5	3000	Green (RoHS & no Sb/Br)	CU NIPDAU	Level-1-260C-UNLIM	-40 to 125	PDTQ	Samples
2U3836L30QDBVRG4Q1	ACTIVE	SOT-23	DBV	5	3000	Green (RoHS & no Sb/Br)	CU NIPDAU	Level-1-260C-UNLIM	-40 to 125	PCAQ	Samples
2U3837E18QDBVRG4Q1	ACTIVE	SOT-23	DBV	5	3000	Green (RoHS & no Sb/Br)	CU NIPDAU	Level-1-260C-UNLIM	-40 to 125	PDOQ	Samples
2U3837J25QDBVRG4Q1	ACTIVE	SOT-23	DBV	5	3000	Green (RoHS & no Sb/Br)	CU NIPDAU	Level-1-260C-UNLIM	-40 to 125	PDRQ	Samples
2U3837K33QDBVRG4Q1	ACTIVE	SOT-23	DBV	5	3000	Green (RoHS & no Sb/Br)	CU NIPDAU	Level-1-260C-UNLIM	-40 to 125	PDUQ	Samples
2U3837L30QDBVRG4Q1	ACTIVE	SOT-23	DBV	5	3000	Green (RoHS & no Sb/Br)	CU NIPDAU	Level-1-260C-UNLIM	-40 to 125	PCBQ	Samples
2U3838E18QDBVRG4Q1	ACTIVE	SOT-23	DBV	5	3000	Green (RoHS & no Sb/Br)	CU NIPDAU	Level-1-260C-UNLIM	-40 to 125	PDQQ	Samples
2U3838J25QDBVRG4Q1	ACTIVE	SOT-23	DBV	5	3000	Green (RoHS & no Sb/Br)	CU NIPDAU	Level-1-260C-UNLIM	-40 to 125	PDPQ	Samples
2U3838K33QDBVRG4Q1	ACTIVE	SOT-23	DBV	5	3000	Green (RoHS & no Sb/Br)	CU NIPDAU	Level-1-260C-UNLIM	-40 to 125	PDVQ	Samples
2U3838L30QDBVRG4Q1	ACTIVE	SOT-23	DBV	5	3000	Green (RoHS & no Sb/Br)	CU NIPDAU	Level-1-260C-UNLIM	-40 to 125	PCCQ	Samples
TPS3836E18QDBVRQ1	ACTIVE	SOT-23	DBV	5	3000	Green (RoHS & no Sb/Br)	CU NIPDAU	Level-1-260C-UNLIM	-40 to 125	PDNQ	Samples
TPS3836H30QDBVRQ1	ACTIVE	SOT-23	DBV	5	3000	Green (RoHS & no Sb/Br)	CU NIPDAU	Level-1-260C-UNLIM	-40 to 125	PHRQ	Samples
TPS3836J25QDBVRQ1	ACTIVE	SOT-23	DBV	5	3000	Green (RoHS & no Sb/Br)	CU NIPDAU	Level-1-260C-UNLIM	-40 to 125	PDSQ	Samples
TPS3836K33QDBVRQ1	ACTIVE	SOT-23	DBV	5	3000	Green (RoHS & no Sb/Br)	CU NIPDAU	Level-1-260C-UNLIM	-40 to 125	PDTQ	Samples

Orderable Device	Status (1)	Package Type	Package Drawing	Pins	Package Qty	Eco Plan (2)	Lead/Ball Finish	MSL Peak Temp (3)	Op Temp (°C)	Top-Side Markings (4)	Samples
TPS3836L30QDBVRQ1	ACTIVE	SOT-23	DBV	5	3000	Green (RoHS & no Sb/Br)	CU NIPDAU	Level-1-260C-UNLIM	-40 to 125	PCAQ	Samples
TPS3837E18QDBVRQ1	OBSOLETE	SOT-23	DBV	5		TBD	Call TI	Call TI	-40 to 125		
TPS3837J25QDBVRQ1	OBSOLETE	SOT-23	DBV	5		TBD	Call TI	Call TI	-40 to 125		
TPS3837K33QDBVRQ1	OBSOLETE	SOT-23	DBV	5		TBD	Call TI	Call TI	-40 to 125		
TPS3837L30QDBVRQ1	ACTIVE	SOT-23	DBV	5	3000	Green (RoHS & no Sb/Br)	CU NIPDAU	Level-1-260C-UNLIM	-40 to 125	PCBQ	Samples
TPS3838E18QDBVRQ1	ACTIVE	SOT-23	DBV	5	3000	Green (RoHS & no Sb/Br)	CU NIPDAU	Level-1-260C-UNLIM	-40 to 125	PDQQ	Samples
TPS3838J25QDBVRQ1	ACTIVE	SOT-23	DBV	5	3000	Green (RoHS & no Sb/Br)	CU NIPDAU	Level-1-260C-UNLIM	-40 to 125	PDPQ	Samples
TPS3838K33QDBVRQ1	ACTIVE	SOT-23	DBV	5	3000	Green (RoHS & no Sb/Br)	CU NIPDAU	Level-1-260C-UNLIM	-40 to 125	PDVQ	Samples
TPS3838L30QDBVRQ1	ACTIVE	SOT-23	DBV	5	3000	Green (RoHS & no Sb/Br)	CU NIPDAU	Level-1-260C-UNLIM	-40 to 125	PCCQ	Samples

(1) The marketing status values are defined as follows:

ACTIVE: Product device recommended for new designs.

LIFEBUY: TI has announced that the device will be discontinued, and a lifetime-buy period is in effect.

NRND: Not recommended for new designs. Device is in production to support existing customers, but TI does not recommend using this part in a new design.

PREVIEW: Device has been announced but is not in production. Samples may or may not be available.

OBSOLETE: TI has discontinued the production of the device.

(2) Eco Plan - The planned eco-friendly classification: Pb-Free (RoHS), Pb-Free (RoHS Exempt), or Green (RoHS & no Sb/Br) - please check <http://www.ti.com/productcontent> for the latest availability information and additional product content details.

TBD: The Pb-Free/Green conversion plan has not been defined.

Pb-Free (RoHS): TI's terms "Lead-Free" or "Pb-Free" mean semiconductor products that are compatible with the current RoHS requirements for all 6 substances, including the requirement that lead not exceed 0.1% by weight in homogeneous materials. Where designed to be soldered at high temperatures, TI Pb-Free products are suitable for use in specified lead-free processes.

Pb-Free (RoHS Exempt): This component has a RoHS exemption for either 1) lead-based flip-chip solder bumps used between the die and package, or 2) lead-based die adhesive used between the die and leadframe. The component is otherwise considered Pb-Free (RoHS compatible) as defined above.

Green (RoHS & no Sb/Br): TI defines "Green" to mean Pb-Free (RoHS compatible), and free of Bromine (Br) and Antimony (Sb) based flame retardants (Br or Sb do not exceed 0.1% by weight in homogeneous material)

(3) MSL, Peak Temp. -- The Moisture Sensitivity Level rating according to the JEDEC industry standard classifications, and peak solder temperature.

(4) Multiple Top-Side Markings will be inside parentheses. Only one Top-Side Marking contained in parentheses and separated by a "~" will appear on a device. If a line is indented then it is a continuation of the previous line and the two combined represent the entire Top-Side Marking for that device.

Important Information and Disclaimer: The information provided on this page represents TI's knowledge and belief as of the date that it is provided. TI bases its knowledge and belief on information provided by third parties, and makes no representation or warranty as to the accuracy of such information. Efforts are underway to better integrate information from third parties. TI has taken and continues to take reasonable steps to provide representative and accurate information but may not have conducted destructive testing or chemical analysis on incoming materials and chemicals. TI and TI suppliers consider certain information to be proprietary, and thus CAS numbers and other limited information may not be available for release.

In no event shall TI's liability arising out of such information exceed the total purchase price of the TI part(s) at issue in this document sold by TI to Customer on an annual basis.

OTHER QUALIFIED VERSIONS OF TPS3836E18-Q1, TPS3836H30-Q1, TPS3836J25-Q1, TPS3836K33-Q1, TPS3836L30-Q1, TPS3837E18-Q1, TPS3837J25-Q1, TPS3837K33-Q1, TPS3837L30-Q1, TPS3838E18-Q1, TPS3838J25-Q1, TPS3838K33-Q1, TPS3838L30-Q1 :

- Catalog: [TPS3836E18](#), [TPS3836H30](#), [TPS3836J25](#), [TPS3836K33](#), [TPS3836L30](#), [TPS3837E18](#), [TPS3837J25](#), [TPS3837K33](#), [TPS3837L30](#), [TPS3838E18](#), [TPS3838J25](#), [TPS3838K33](#), [TPS3838L30](#)
- Enhanced Product: [TPS3836J25-EP](#), [TPS3836L30-EP](#), [TPS3837K33-EP](#)

NOTE: Qualified Version Definitions:

- Catalog - TI's standard catalog product
- Enhanced Product - Supports Defense, Aerospace and Medical Applications

TAPE AND REEL INFORMATION

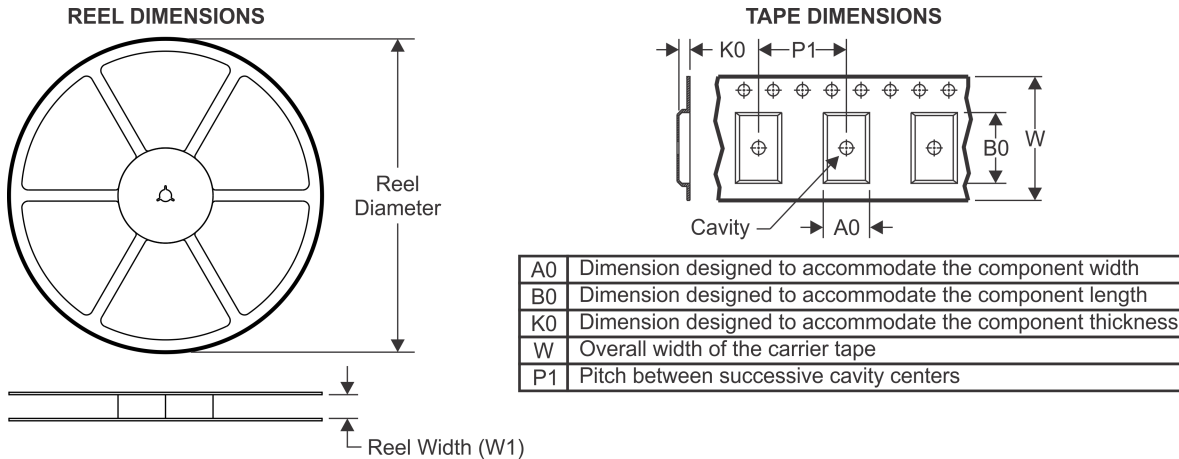

QUADRANT ASSIGNMENTS FOR PIN 1 ORIENTATION IN TAPE

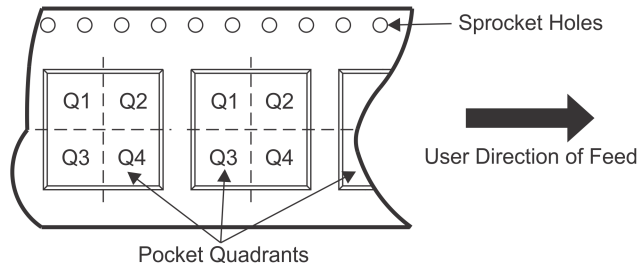

*All dimensions are nominal

Device	Package Type	Package Drawing	Pins	SPQ	Reel Diameter (mm)	Reel Width W1 (mm)	A0 (mm)	B0 (mm)	K0 (mm)	P1 (mm)	W (mm)	Pin1 Quadrant
2U3836E18QDBVRG4Q1	SOT-23	DBV	5	3000	180.0	9.0	3.15	3.2	1.4	4.0	8.0	Q3
2U3836H30QDBVRG4Q1	SOT-23	DBV	5	3000	180.0	9.0	3.15	3.2	1.4	4.0	8.0	Q3
2U3836J25QDBVRG4Q1	SOT-23	DBV	5	3000	180.0	9.0	3.15	3.2	1.4	4.0	8.0	Q3
2U3836K33QDBVRG4Q1	SOT-23	DBV	5	3000	180.0	9.0	3.15	3.2	1.4	4.0	8.0	Q3
2U3836L30QDBVRG4Q1	SOT-23	DBV	5	3000	180.0	9.0	3.15	3.2	1.4	4.0	8.0	Q3
2U3837E18QDBVRG4Q1	SOT-23	DBV	5	3000	180.0	9.0	3.15	3.2	1.4	4.0	8.0	Q3
2U3837J25QDBVRG4Q1	SOT-23	DBV	5	3000	180.0	9.0	3.15	3.2	1.4	4.0	8.0	Q3
2U3837K33QDBVRG4Q1	SOT-23	DBV	5	3000	180.0	9.0	3.15	3.2	1.4	4.0	8.0	Q3
2U3837L30QDBVRG4Q1	SOT-23	DBV	5	3000	180.0	9.0	3.15	3.2	1.4	4.0	8.0	Q3
2U3838E18QDBVRG4Q1	SOT-23	DBV	5	3000	180.0	9.0	3.15	3.2	1.4	4.0	8.0	Q3
2U3838J25QDBVRG4Q1	SOT-23	DBV	5	3000	180.0	9.0	3.15	3.2	1.4	4.0	8.0	Q3
2U3838K33QDBVRG4Q1	SOT-23	DBV	5	3000	180.0	9.0	3.15	3.2	1.4	4.0	8.0	Q3
2U3838L30QDBVRG4Q1	SOT-23	DBV	5	3000	180.0	9.0	3.15	3.2	1.4	4.0	8.0	Q3
TPS3836E18QDBVRQ1	SOT-23	DBV	5	3000	180.0	9.0	3.15	3.2	1.4	4.0	8.0	Q3
TPS3836H30QDBVRQ1	SOT-23	DBV	5	3000	180.0	9.0	3.15	3.2	1.4	4.0	8.0	Q3
TPS3836J25QDBVRQ1	SOT-23	DBV	5	3000	180.0	9.0	3.15	3.2	1.4	4.0	8.0	Q3
TPS3836K33QDBVRQ1	SOT-23	DBV	5	3000	180.0	9.0	3.15	3.2	1.4	4.0	8.0	Q3
TPS3836L30QDBVRQ1	SOT-23	DBV	5	3000	180.0	9.0	3.15	3.2	1.4	4.0	8.0	Q3

Device	Package Type	Package Drawing	Pins	SPQ	Reel Diameter (mm)	Reel Width W1 (mm)	A0 (mm)	B0 (mm)	K0 (mm)	P1 (mm)	W (mm)	Pin1 Quadrant
TPS3837L30QDBVRQ1	SOT-23	DBV	5	3000	180.0	9.0	3.15	3.2	1.4	4.0	8.0	Q3
TPS3838E18QDBVRQ1	SOT-23	DBV	5	3000	180.0	9.0	3.15	3.2	1.4	4.0	8.0	Q3
TPS3838J25QDBVRQ1	SOT-23	DBV	5	3000	180.0	9.0	3.15	3.2	1.4	4.0	8.0	Q3
TPS3838K33QDBVRQ1	SOT-23	DBV	5	3000	180.0	9.0	3.15	3.2	1.4	4.0	8.0	Q3
TPS3838L30QDBVRQ1	SOT-23	DBV	5	3000	180.0	9.0	3.15	3.2	1.4	4.0	8.0	Q3

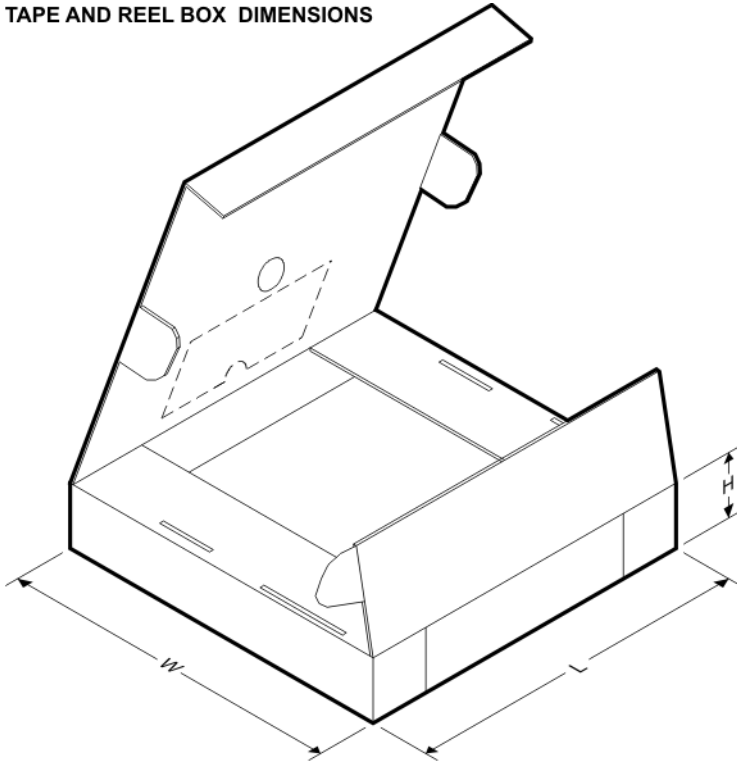
TAPE AND REEL BOX DIMENSIONS

*All dimensions are nominal

Device	Package Type	Package Drawing	Pins	SPQ	Length (mm)	Width (mm)	Height (mm)
2U3836E18QDBVRG4Q1	SOT-23	DBV	5	3000	182.0	182.0	20.0
2U3836H30QDBVRG4Q1	SOT-23	DBV	5	3000	182.0	182.0	20.0
2U3836J25QDBVRG4Q1	SOT-23	DBV	5	3000	182.0	182.0	20.0
2U3836K33QDBVRG4Q1	SOT-23	DBV	5	3000	182.0	182.0	20.0
2U3836L30QDBVRG4Q1	SOT-23	DBV	5	3000	182.0	182.0	20.0
2U3837E18QDBVRG4Q1	SOT-23	DBV	5	3000	182.0	182.0	20.0
2U3837J25QDBVRG4Q1	SOT-23	DBV	5	3000	182.0	182.0	20.0
2U3837K33QDBVRG4Q1	SOT-23	DBV	5	3000	182.0	182.0	20.0
2U3837L30QDBVRG4Q1	SOT-23	DBV	5	3000	182.0	182.0	20.0
2U3838E18QDBVRG4Q1	SOT-23	DBV	5	3000	182.0	182.0	20.0
2U3838J25QDBVRG4Q1	SOT-23	DBV	5	3000	182.0	182.0	20.0
2U3838K33QDBVRG4Q1	SOT-23	DBV	5	3000	182.0	182.0	20.0

Device	Package Type	Package Drawing	Pins	SPQ	Length (mm)	Width (mm)	Height (mm)
2U3838L30QDBVRG4Q1	SOT-23	DBV	5	3000	182.0	182.0	20.0
TPS3836E18QDBVRQ1	SOT-23	DBV	5	3000	182.0	182.0	20.0
TPS3836H30QDBVRQ1	SOT-23	DBV	5	3000	182.0	182.0	20.0
TPS3836J25QDBVRQ1	SOT-23	DBV	5	3000	182.0	182.0	20.0
TPS3836K33QDBVRQ1	SOT-23	DBV	5	3000	182.0	182.0	20.0
TPS3836L30QDBVRQ1	SOT-23	DBV	5	3000	182.0	182.0	20.0
TPS3837L30QDBVRQ1	SOT-23	DBV	5	3000	182.0	182.0	20.0
TPS3838E18QDBVRQ1	SOT-23	DBV	5	3000	182.0	182.0	20.0
TPS3838J25QDBVRQ1	SOT-23	DBV	5	3000	182.0	182.0	20.0
TPS3838K33QDBVRQ1	SOT-23	DBV	5	3000	182.0	182.0	20.0
TPS3838L30QDBVRQ1	SOT-23	DBV	5	3000	182.0	182.0	20.0

DBV (R-PDSO-G5)

PLASTIC SMALL-OUTLINE PACKAGE

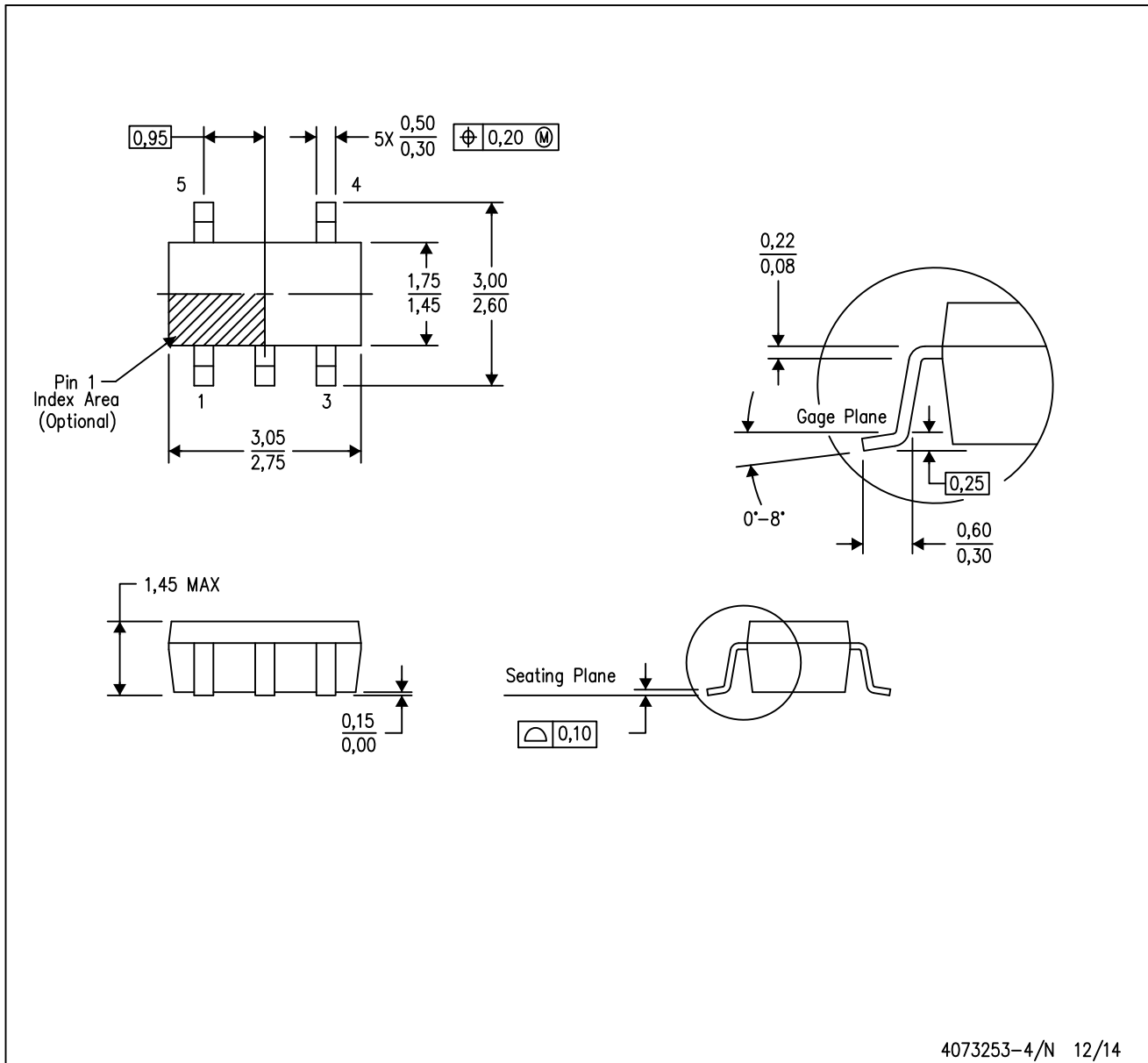

- NOTES:
- A. All linear dimensions are in millimeters.
 - B. This drawing is subject to change without notice.
 - C. Body dimensions do not include mold flash or protrusion. Mold flash and protrusion shall not exceed 0.15 per side.
 - D. Falls within JEDEC MO-178 Variation AA.

DBV (R-PDSO-G5)

PLASTIC SMALL OUTLINE



- NOTES:
- A. All linear dimensions are in millimeters.
 - B. This drawing is subject to change without notice.
 - C. Customers should place a note on the circuit board fabrication drawing not to alter the center solder mask defined pad.
 - D. Publication IPC-7351 is recommended for alternate designs.
 - E. Laser cutting apertures with trapezoidal walls and also rounding corners will offer better paste release. Customers should contact their board assembly site for stencil design recommendations. Example stencil design based on a 50% volumetric metal load solder paste. Refer to IPC-7525 for other stencil recommendations.

IMPORTANT NOTICE

Texas Instruments Incorporated and its subsidiaries (TI) reserve the right to make corrections, enhancements, improvements and other changes to its semiconductor products and services per JESD46, latest issue, and to discontinue any product or service per JESD48, latest issue. Buyers should obtain the latest relevant information before placing orders and should verify that such information is current and complete. All semiconductor products (also referred to herein as "components") are sold subject to TI's terms and conditions of sale supplied at the time of order acknowledgment.

TI warrants performance of its components to the specifications applicable at the time of sale, in accordance with the warranty in TI's terms and conditions of sale of semiconductor products. Testing and other quality control techniques are used to the extent TI deems necessary to support this warranty. Except where mandated by applicable law, testing of all parameters of each component is not necessarily performed.

TI assumes no liability for applications assistance or the design of Buyers' products. Buyers are responsible for their products and applications using TI components. To minimize the risks associated with Buyers' products and applications, Buyers should provide adequate design and operating safeguards.

TI does not warrant or represent that any license, either express or implied, is granted under any patent right, copyright, mask work right, or other intellectual property right relating to any combination, machine, or process in which TI components or services are used. Information published by TI regarding third-party products or services does not constitute a license to use such products or services or a warranty or endorsement thereof. Use of such information may require a license from a third party under the patents or other intellectual property of the third party, or a license from TI under the patents or other intellectual property of TI.

Reproduction of significant portions of TI information in TI data books or data sheets is permissible only if reproduction is without alteration and is accompanied by all associated warranties, conditions, limitations, and notices. TI is not responsible or liable for such altered documentation. Information of third parties may be subject to additional restrictions.

Resale of TI components or services with statements different from or beyond the parameters stated by TI for that component or service voids all express and any implied warranties for the associated TI component or service and is an unfair and deceptive business practice. TI is not responsible or liable for any such statements.

Buyer acknowledges and agrees that it is solely responsible for compliance with all legal, regulatory and safety-related requirements concerning its products, and any use of TI components in its applications, notwithstanding any applications-related information or support that may be provided by TI. Buyer represents and agrees that it has all the necessary expertise to create and implement safeguards which anticipate dangerous consequences of failures, monitor failures and their consequences, lessen the likelihood of failures that might cause harm and take appropriate remedial actions. Buyer will fully indemnify TI and its representatives against any damages arising out of the use of any TI components in safety-critical applications.

In some cases, TI components may be promoted specifically to facilitate safety-related applications. With such components, TI's goal is to help enable customers to design and create their own end-product solutions that meet applicable functional safety standards and requirements. Nonetheless, such components are subject to these terms.

No TI components are authorized for use in FDA Class III (or similar life-critical medical equipment) unless authorized officers of the parties have executed a special agreement specifically governing such use.

Only those TI components which TI has specifically designated as military grade or "enhanced plastic" are designed and intended for use in military/aerospace applications or environments. Buyer acknowledges and agrees that any military or aerospace use of TI components which have **not** been so designated is solely at the Buyer's risk, and that Buyer is solely responsible for compliance with all legal and regulatory requirements in connection with such use.

TI has specifically designated certain components as meeting ISO/TS16949 requirements, mainly for automotive use. In any case of use of non-designated products, TI will not be responsible for any failure to meet ISO/TS16949.

Products

Audio	www.ti.com/audio
Amplifiers	amplifier.ti.com
Data Converters	dataconverter.ti.com
DLP® Products	www.dlp.com
DSP	dsp.ti.com
Clocks and Timers	www.ti.com/clocks
Interface	interface.ti.com
Logic	logic.ti.com
Power Mgmt	power.ti.com
Microcontrollers	microcontroller.ti.com
RFID	www.ti-rfid.com
OMAP Applications Processors	www.ti.com/omap
Wireless Connectivity	www.ti.com/wirelessconnectivity

Applications

Automotive and Transportation	www.ti.com/automotive
Communications and Telecom	www.ti.com/communications
Computers and Peripherals	www.ti.com/computers
Consumer Electronics	www.ti.com/consumer-apps
Energy and Lighting	www.ti.com/energy
Industrial	www.ti.com/industrial
Medical	www.ti.com/medical
Security	www.ti.com/security
Space, Avionics and Defense	www.ti.com/space-avionics-defense
Video and Imaging	www.ti.com/video

TI E2E Community

e2e.ti.com